

# P.H.R



**MANUAL CHAIN HOIST  
FROM 250 to 20 000 kg**



# HOOK-IN UNIT/BLOCK

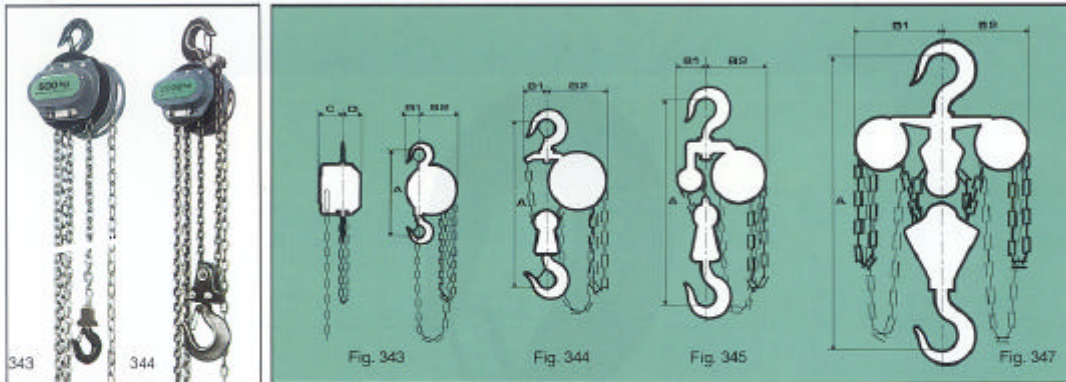

The P.H.R. is robust and is constructed entirely from steel. Mechanical parts are protected by integral casings. The P.H.R. gear mechanism has been designed to enable the operator to lift loads up to 20 tonnes with a minimum of effort.

## GENERAL DESIGN

- Hand wheel covers, protects the handwheel and it guide, and secures the chain.
- Mechanical components, (axles and gear wheels) are manufactured from hardened steel.
- Chain sprocket is ball-race mounted.
- Lifting and suspension hooks in forged steel, mounted on ball-joints, and are fitted with safety catches.
- Automatic braking using Ferodo washer.
- Lower hook limit is maintained by fixed stop on load chain.
- High resistance lifting chain, with minimum safety coefficient of 5.

**OPTIONS** : Load limiter, stainless chain, chrome-plated block unit.

P.H.R. hoists can be easily suspended from one of our range of hoist trolleys, for travelling along a monorail beam. See our leaflet J.12.U.

The P.H.R. is distributed in more than 70 countries.

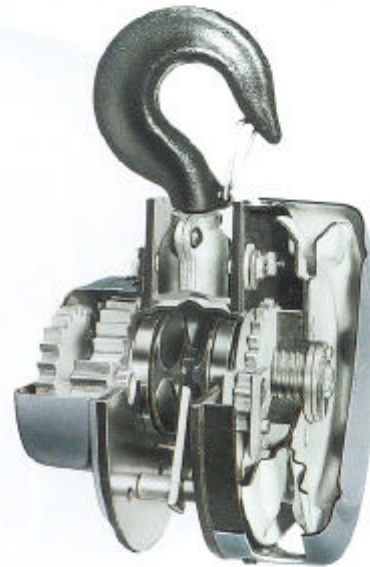

343

## GENERAL CHARACTERISTICS AND DIMENSIONS

Fig	Capacity kg	HOIST TYPE	LIFTING CHAIN			HAND CHAIN Dia. x pitch mm	WEIGHT			Chain weight per metre lit kg	DIMENSIONS					Effort on hand chain kg	Hand chain movement for 1m lift m
			No. of falls	Dia. x pitch mm	Chain grade h. bar		Without chain kg	Lit 3 m kg	A mm		B1 mm	B2 mm	C mm	D mm			
343	250	PHR 0	1	5 x 15	50	5 x 27,1	4	10	2	300	50	100	73	60	20	19	
	500	PHR 1	1	6,5 x 19,5	50	5 x 27,1	9	14	2,5	320	65	115	93	71	26	29	
	1 000	PHR 1	1	6,5 x 19,5	80	5 x 27,1	10	15	2,5	350	65	115	93	71	23	43	
344	1 600	PHR 1	2	6,5 x 19,5	80	5 x 27,1	12	20	3,5	450	60	155	93	71	25	86	
	2 000	PHR 1	2	6,5 x 19,5	80	5 x 27,1	13	21	3,5	470	60	155	93	71	32	86	
343	2 000	PHR 3	1	11,5 x 33	80	5 x 27,1	25	39	4,5	485	105	210	115	100	23	98	
	3 200	PHR 3	1	11,5 x 33	80	5 x 27,1	25	39,5	4,5	535	105	210	115	100	37	98	
344	4 000	PHR 3	2	11,5 x 33	80	5 x 27,1	42	63	7,5	740	115	310	115	100	32	196	
	5 000	PHR 3	2	11,5 x 33	80	5 x 27,1	42	63	7,5	740	115	310	115	100	32	196	
	6 300	PHR 3	2	11,5 x 33	80	5 x 27,1	44	65	7,5	750	115	310	115	100	40	196	
345	8 000	PHR 3	3	11,5 x 33	80	5 x 27,1	64	104	10,5	880	150	330	115	100	38	294	
	10 000	PHR 3	4	11,5 x 33	80	5 x 27,1	102	141	14	1000	185	375	95	120	39	332	
	12 500	PHR 3	4	11,5 x 33	80	5 x 27,1	114	153	14	1050	185	375	95	120	49	332	
347	16 000	PHR 3	2 x 4	11,5 x 33	80	5 x 27,1	295	373	27,5	1370	418	418	200	200	30*	410*	
	20 000	PHR 3	2 x 4	11,5 x 33	80	5 x 27,1	295	373	27,5	1370	418	418	200	200	38*	410*	

\* For one block

# HOIST WITH BUILT IN TROLLEY

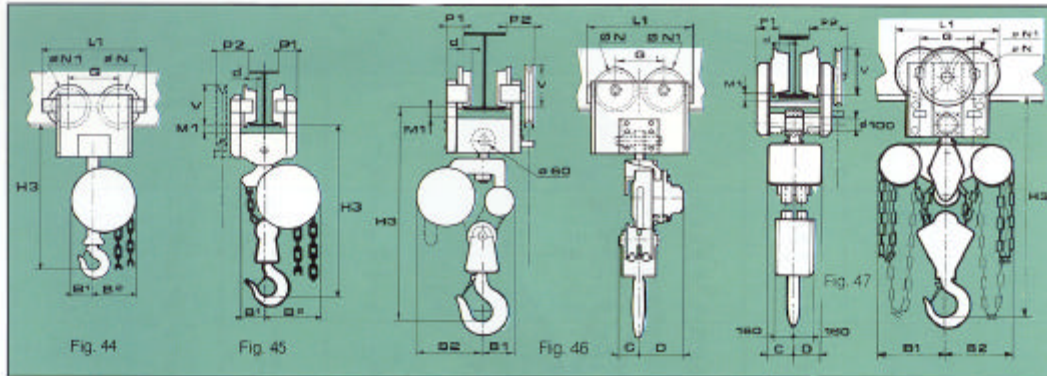

The P.H.R. hoist is supplied built into a trolley to form an integral unit. This solution is recommended when the headroom must be minimised or when the hoist should not be easy to release from the trolley.

#### GENERAL DESIGN

- Heavy duty, rigid, steel sheet side plates.
- Cast iron wheels, ball-race mounted, removable axles, machined teeth, wheel treads are compatible with any type of monorail beam.
- Steel crosshead for assembly to block.
- Adjustable flange width, using packing plates or washers.

enabling trolleys to run on a range of flange sizes.

- Chain travel trolleys. A hand wheel with deep flanges, driven by an endless chain loop, drives the wheels through a gear wheel with machined teeth. Two chain guides retain hand chain.

#### PRACTICAL RECOMMENDATIONS

The user must ensure that the beam selected is suitable for all loads imposed, particularly local bending of the lower flange. Beam widths given in the tables above are only a guide and do not, in any way, imply the manufacturer's responsibility concerning the choice of beam and its resistance.

#### DIMENSIONS (mm)

Capacity kg	CROSSHEAD P/N	PHR TYPE	d	H3	B1	B2	C	D	L1	M1	G	aN	aN1	P1	P2	V
500 fig. 44	051-052	1	18,5	346	65	115	93	71	200	19	100	70	87	51	78	85
	201	1	18	378	65	115	93	71	230	25	116	70	99	51	83	102
	103	1	18	378	65	115	93	71	230	27	116	70	99	51	83	102
	104, 5, 7	1	25	404	65	115	93	71	285	35	144	100	127	42	82	115
1 000 fig. 44	101-201	1	18	390	65	115	93	71	230	25	116	70	99	51	83	102
	103	1	18	390	65	115	93	71	230	27	116	70	99	51	83	102
	104, 5, 7	1	25	416	65	115	93	71	285	35	144	100	127	42	83	115
1 600 fig. 45	201-103	1	25	500	60	155	93	71	285	35	144	100	127	51	82	115
	104, 5, 7	1	25	520	60	155	93	71	285	35	144	100	127	42	83	115
2 000 fig. 46	201-103	1	25	520	60	155	93	71	285	35	144	100	127	51	82	115
	104, 5, 7	1	25	545	60	155	93	71	285	35	144	100	127	42	83	115
2 000 fig. 44	201-103	3	25	540	105	210	115	100	285	35	144	100	127	51	120	115
	104, 5, 7	3	25	560	105	210	115	100	285	35	144	100	127	42	83	115
3 200 fig. 44	32111-32221	3	32	615	105	210	115	100	370	45	188	140	167	56	130	121
	32331-32421															
	32531-32641															
4 000 fig. 45	32111-32221	3	32	775	115	310	115	100	415	40	210	140	167	75	112	209
	32331-32421															
	32531-32641															
5 000 fig. 45	32111-32221	3	32	775	115	310	115	100	415	40	210	140	167	75	112	209
	32331-32421															
	32531-32641															
6300 fig. 46	32112-32222	3	32	790	95	295	115	100	415	40	210	140	167	75	112	209
	32332-32422															
	32532-32642															
8 000 fig. 46	80112-80212	3	35	1005	150	330	115	100	445	50	210	160	195	111	130	183
	80312-80412															
	80512															
10 000 fig. 46	80112-80212	3	35	1080	185	375	95	120	445	50	210	160	195	111	130	183
	80312-80412															
	80512															
12 500 fig. 46	80113-80213	3	35	1120	185	375	95	120	445	50	210	160	195	111	130	183
	80313-80413															
	80513															
16 000 20 000 fig. 47	Depending upon beam width - specify with order.	3	55	1400	418	418	200	200	710	45	370	300	340	135	201	320

# P.H.R

## GENERAL CHARACTERISTICS OF HOIST WITH BUILT IN TROLLEY

Capacity  kg	HOIST TYPE	Crosshead		Beam rail		Track radius		WEIGHT lt 3 m			
		N°	Width	Width min-max	Height	IPN min	IPE min	Push travel	Chen travel		
			mm	mm	mm	m	m	kg	kg		
500	PHR 1	051	73	50-91	100	1	1,5	21	26		
		052	95	98-106	100	1	1,5	21	26		
		201	106	81-113	120	1	2	25	31		
		103	143	118-143	120	2	2	25	31		
		104	167	147-190	160	1,5	2	33	39		
		105	217	198-260	160	0	2	to	to		
		107	297	280-300	160	0	2	36	42		
1 000	PHR 1	101	90	64-74	120	1	2	25	31		
		201	106	81-113	120	1	2	25	31		
		103	143	118-143	120	2	2	25	31		
		104	167	147-190	160	1,5	2	34	39		
		105	217	198-260	160	0	2	34	39		
		107	297	280-300	160	0	2	34	39		
		101	106	81-113	160	2	2,5				
103	143	118-143	160	2	2,5	36	42				
104	167	147-190	160	1,5	2	to	to				
105	217	198-260	160	0	2	39	45				
107	297	280-300	160	0	2						
2 000	PHR 3	201	106	81-113	160	2	2,5	58	63		
		103	143	118-143	160	2	2,5	58	63		
		104	167	147-190	160	1,5	2	58	63		
		105	217	198-260	160	0	2	58	63		
		107	297	280-300	160	0	2	58	63		
		32111	128	89-120	180	2,5	2,5				
		32221	163	125-160	180	2,5	2,5	84	90		
32331	205	166-200	180	2,5	2,5	to	to				
32421	242	206-240	200	0	2						
32531	288	248-280	200	0	2	88	94				
32641	330	288-310	210	0	2						
4 000	PHR 3	32111	128	89-120	230	2,5	2,5				
		32221	163	125-160	230	2,5	2,5	127	135		
		32331	205	166-200	230	2,5	2,5	to	to		
		32421	242	206-240	230	2,5	2,5	to	139		
		32531	288	248-280	230	-	2,5	131			
		32641	330	288-310	230	-	2,5				
		32111	128	89-120	230	2,5	2,5				
32221	163	125-160	230	2,5	2,5	129	137				
32331	205	166-200	230	2,5	2,5	to	to				
32421	242	206-240	230	2,5	2,5						
32531	288	248-280	230	-	2,5	133	141				
32641	330	288-310	230	-	2,5						
6 300	PHR 3	32112	128	89-120	230	2,5	2,5	-	-		
		32222	163	125-160	230	2,5	2,5	-	175		
		32332	205	166-200	230	2,5	2,5	-	to		
		32422	242	206-240	230	2,5	2,5	-	183		
		32532	288	248-280	230	-	2,5	-	-		
		32642	330	288-310	230	-	2,5	-	-		
		80112	162	98-137	200	6	6	-	-		
80212	202	140-178	200	6	6	-	284 to				
80312	242	180-218	200	6	6	-	272				
80412	284	220-260	200	-	6	-	301 to				
80512	330	268-310	200	-	6	-	309				
12 500	PHR 3	80113	162	98-137	200	6	6	-	-		
		80213	202	140-178	200	6	6	-	325		
		80313	242	180-218	200	6	6	-	to		
		80413	284	220-260	200	-	6	-	331		
		80513	330	268-310	200	-	6	-	-		
		16 000 and 20 000	PHR 3	Depending upon beam width, specify with order		155-210 215-300	340	-	-	-	719

Characteristics and dimensions may be modified without notice.



CHAIN HOIST DEPARTMENT  
2, Bd de l'Industrie - B.P. 59 - 28501 VERNOUJILLET CEDEX - FRANCE  
Tél. (33) 2.37.38.95.95 - Fax (33) 2.37.38.95.99  
Internet : <http://www.verlinda.com>