

MANUAL WINCHES

MA - MB

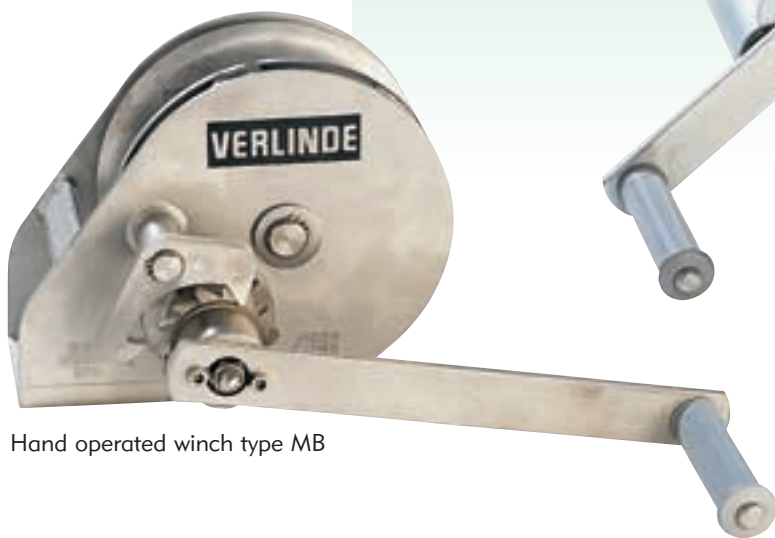

Hand operated winch type MB



Hand operated winch type MA

for lifting and traction
from 300 to 1350 kg loads capacity



2, boulevard de l'Industrie - B.P. 59 - 28501 Vernouillet cedex - France

Phone : (33) 02 37 38 95 95 - Fax : (33) 02 37 38 95 99

Internet : www.verlinde.fr

JV 03 2002 11 U GB

Hand-operated winch type MA

For loads from
300 to 1000 kg

Wall mounted hand-operated winch MA	Type	MA1	MA2	MA3	MA4
Lifting capacity	[kg]	300	500	750	1000

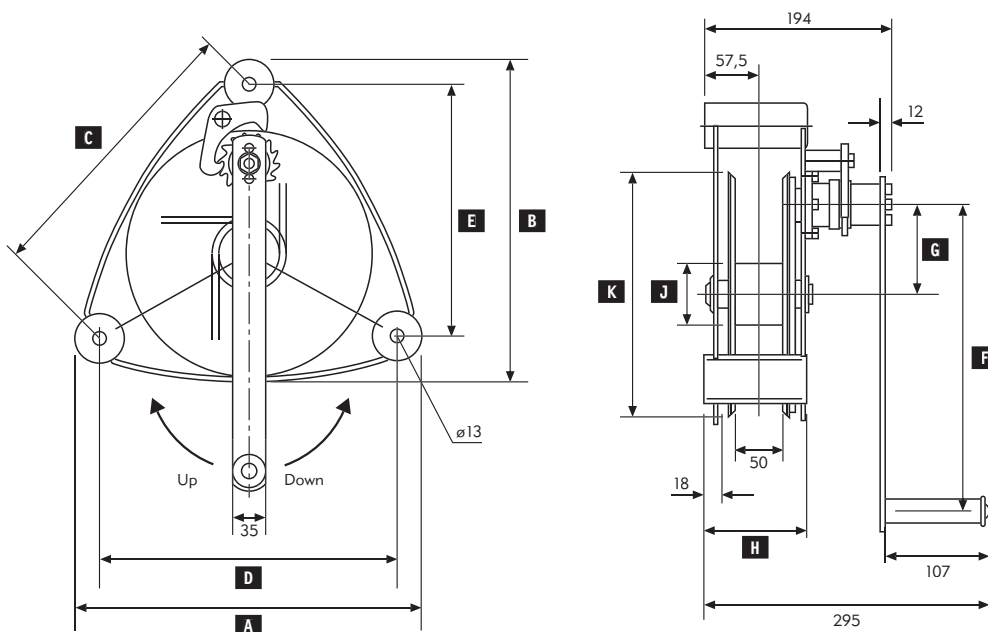

Model	Load	A	B	C	D	E	F	G	H	J	K
	[kg]	[mm]	[mm]	[mm]	[mm]	[mm]	[mm]	[mm]	[mm]	[mm]	[mm]
MA1	300	274	262	234	234	203	200	58,6	109,5	63	183
MA2	500	274	262	234	234	203	250	58,6	109,5	63	183
MA3	750	357	337	306	306	265	250	92,5	107	63,5	255
MA4	1000	357	337	306	306	265	320	92,5	107	63,5	255

Model	MA1	MA2	MA3	MA4	
FEM gear set per DIN 15020/1	1Em	1Em	1Em	1Em	
Lifting capacity on first layer	[daN]	300	500	750	1000
Lifting capacity on last layer	[daN]	130	230	270	360
Recommended Cable* - DIN 3060 FE-znk 1770 sZ-SPA	ø[mm]	5	6	7	7
Total winding capacity	[m]	28	20	26	26
Max. number of layers		10	8	10	10
Effort required on crank	[daN]	13	17	17	18
Travel per crank turn	[mm]	57	55	45	45
Weight	[kg]	9,0	9,6	13,0	13,6
Safety with load		Brake engaged			
Operating temperature range		-20 °C ÷ +40 °C			

*Winch supplied without cable.

Common ch

Frame.

The MA and MB winches are available in two versions, with a galvanized steel frame or with certain MB-types winches with galvanized steel frames (MB2 Stl. St. 1000 kg).

Gearing.

All of the gears used with these winches are spur gears providing the most efficient force transmission or pulling force transmission.

Mounting.

Depending on the model, the winch can be mounted through 3 or 4 widely-separated anchoring points. The MB model can be mounted vertically or horizontally; the MA model is mounted vertically.



Brake.



The local automatic brake prevents the load from falling.

Crank.



Rotating plastic cover protects the crank arm from dirt.

Disengageable drum.

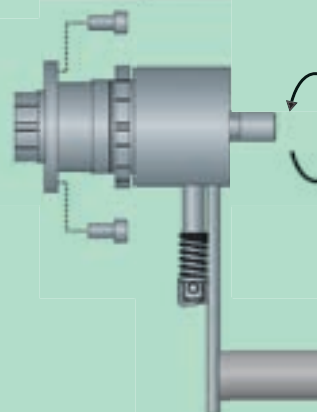

Characteristics

are supplied, in their standard
d steel frame. Optionally,
are available with stainless
650 kg and MB4 stL. St.

in the MA and MB winches
the user with optimum lifting
with low operating noise.

the winches are secured
separated points for balances
can be mounted vertically
model is mounted vertically.



is maintained by an
mechanically-engaged brake for
and lowering.

g crank with comfortable
covered handle. Long crank
provides maximum force.

Optionally, certain MB
winches (900 and
1350 kg) come
equipped with a safety
device which
automatically cancels
the clutch release with
load by means of a
small easily accessible
lever.

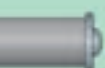

Hand-operated winch type MB

For loads from
400 to 1350 kg

Standard model	Type	MB5	MB3	MB2	MB1
Lifting capacity	[kg]	1350	900	650	400

With disengageable brake	Type	MB5 D	MB3 D
Lifting capacity	[kg]	1350	900

Anti-corrosion model	Type	MB4 Inox	MB2 Inox
Lifting capacity	[kg]	1000	650

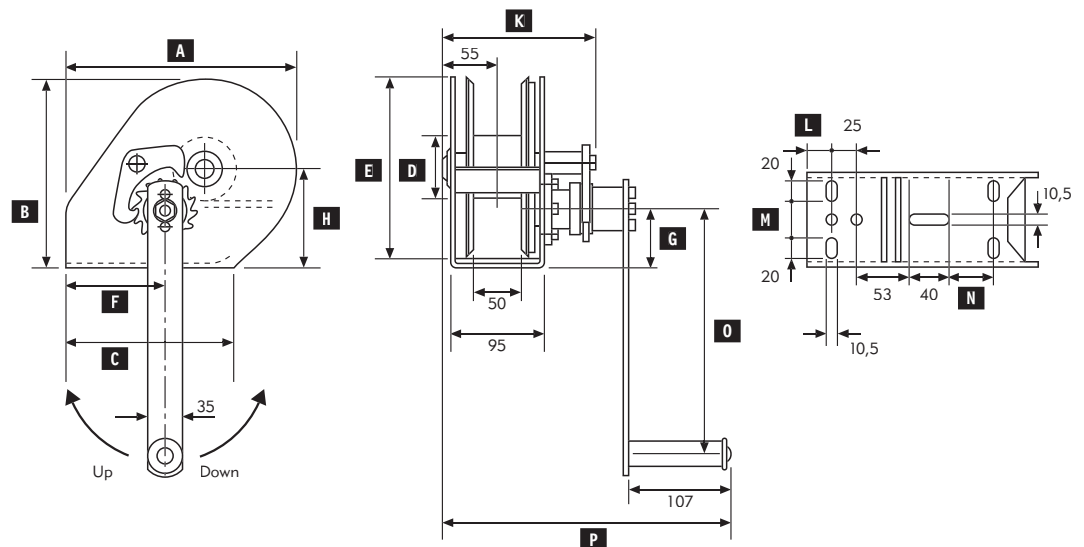

MODEL	A	B	C	D	E	F	G	H	K	L	M	N	O	P
MB1	232	192	170	63,5	183	100	58	100	192	25	38	-	200	293
MB2 MB2 Inox	232	192	170	63,5	183	100	58	100	192	25	38	-	250	293
MB3	232	192	170	63,5	183	100	58	100	192	25	38	-	320	293
MB3 D	232	192	170	63,5	183	100	58	100	226	25	38	-	320	303
MB4 Inox	273	266	240	63,5	255	78	75	138	190	35	30	53	250	291
MB5	273	266	240	63,5	255	78	75	138	192	35	30	53	320	293
MB5 D	273	266	240	63,5	255	78	75	138	226	35	30	53	320	303

Model	MB1	MB2 MB2 inox	MB3 MB3 D	MB4 Inox	MB5 MB5 D
Gear set per DIN 15020	1Em	1Em	1Em	1Em	1Em
Lifting capacity on first layer	400 daN	650 daN	900 daN	1000 daN	1350 daN
Lifting capacity on last layer	180 daN	290 daN	400 daN	360 daN	480 daN
Recommended Cable* - DIN 3060 FE-znk 1770 sZ-SPA	ø5 mm	MB2 ø6 mm	ø7 mm		
Recommended Cable* - DIN 3060 SE-znk 2160 sZ-SPA					ø7 mm
Recommended Cable* - DIN 3060 FE bk 1770 sZ-SPA (1.4401)		MB2 inox ø6 mm		ø7 mm	
Total winding capacity	28 m	20 m	14 m	26 m	26 m
Max. number of layers	10	8	7	10	10
Effort required on crank	18 daN	22 daN	24 daN	24 daN	24 daN
Travel per crank turn	57	55	58	45	45
Safety with load		Brake engaged			
Operating temperature range		-20 °C à +40 °C			

*Winch supplied without cable.

advice as to the use of hand-operated winches

recommandations for pulling or traction operation



2, boulevard de l'Industrie - B.P. 59 - 28501 Vernouillet cedex - France
Téléphone : (33) 02 37 38 95 95 - Télécopieur : (33) 02 37 38 95 99

Internet : www.verlinde.fr
JV 032002 11 U GB

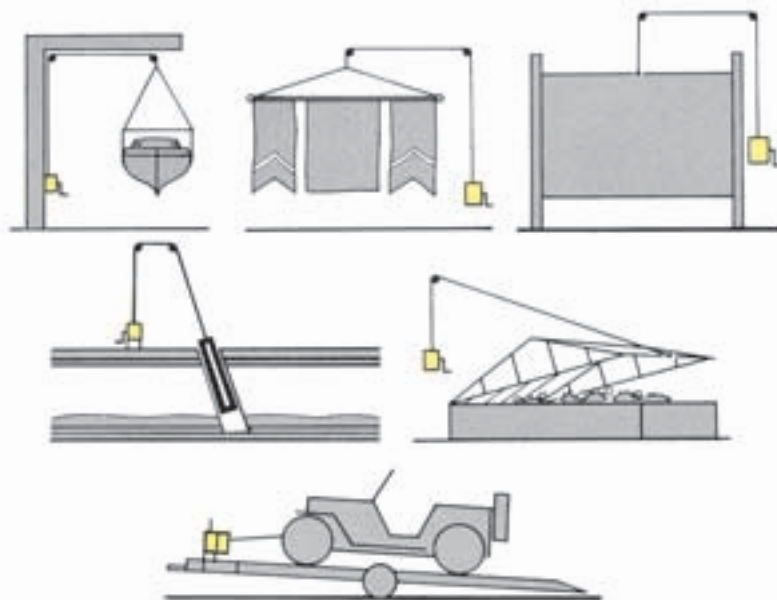

- The **MA** worm-gear and **MB** gearing type hand-operated winches have been designed to meet all the requirements of the lifting and traction market. This type of winch can be used either for hoisting, with all the safety measures necessary to comply with existing standards, or for "traction or pulling" with the same sturdiness as hoisting.

NB : The tractive capacity shown is valid for a unit operating under optimum conditions.

Important : Three turns of rope should always remain wound on the drum at the end of travel. Winches are delivered without rope as standard.

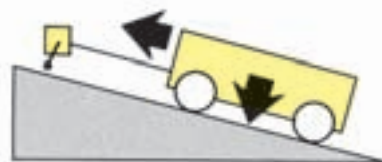

During traction, the tension on the rope should never exceed the winch's rated lifting load capacity.

- **Optimum working conditions:**
Calculation of the load which can be travelled varies according to the conditions of the installation, considering the following parameters:
 - whether or not the wheels are mounted on ball bearings
 - diameter of the wheels (the larger the diameter the less the pull)
 - the materials of which the wheel is made and what it runs on determines the travelling coefficient (rail, wood, asphalt, concrete or sand) and the slope, if any.

DISTRIBUTED BY

